

DO NOT SCALE - USE DIMENSIONS ONLY *NOT B.O. INDICATES NOT FURNISHED BY CB ER
 DO NOT USE FOR CONSTRUCTION UNLESS APPROVED BELOW
 THIS DRAWING IS THE PROPERTY OF CB ENERGY RECOVERY AND IS LOANED ON CONDITION THAT IT SHALL NOT BE COPIED OR REPRODUCED IN WHOLE OR IN PART OR DISCLOSED TO ANY THIRD PARTY OR USED IN ANY WAY WITHOUT THE WRITTEN CONSENT OF CB ENERGY RECOVERY. ANY EQUIPMENT OR MATERIAL SHOWN, BUT NOT FURNISHED BY CB ENERGY RECOVERY IS FOR ILLUSTRATING THE APPLICATION, AND CB ENERGY RECOVERY ACCEPTS NO RESPONSIBILITY AS TO INSTALLATION OR OPERATION OF SUCH EQUIPMENT OR MATERIALS.

REV.	DATE	DESCRIPTION	DWN	CHK	APPR

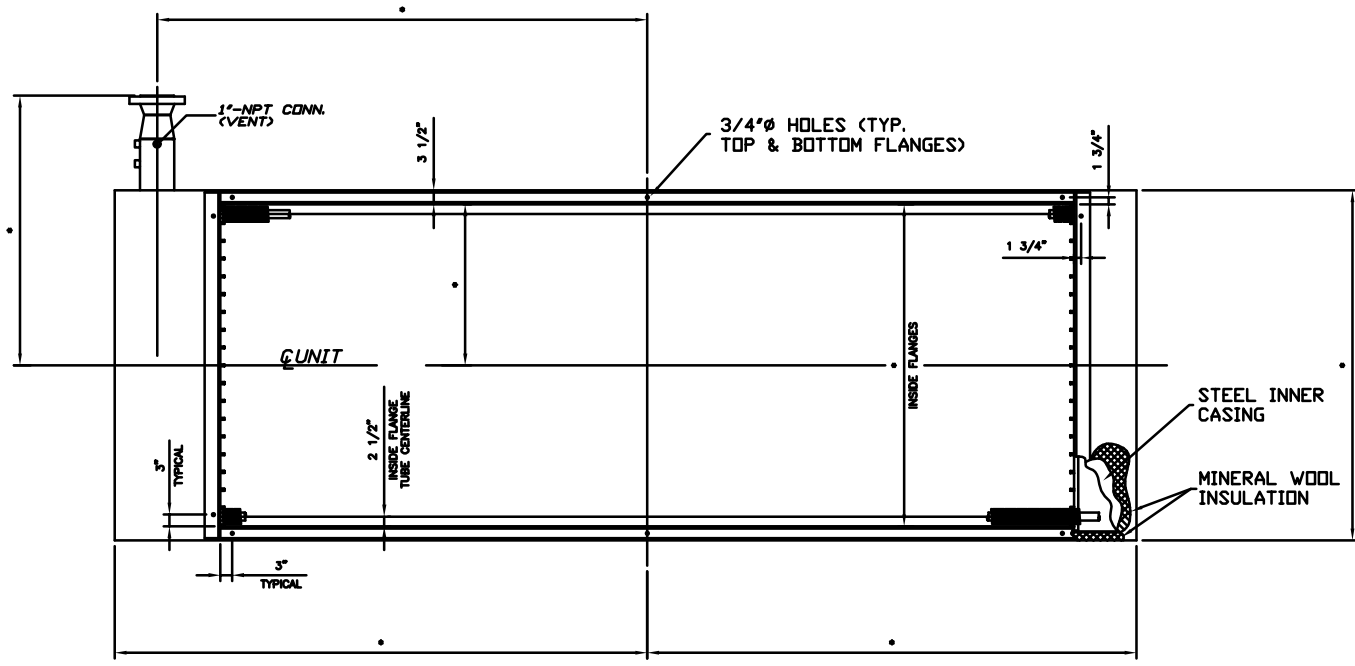

PLAN VIEW

NOTES

1. ALL INNER CASING JOINTS TO BE SEAL WELDED.
2. DIMENSIONS WILL CHANGE WITH HEADER SIZING AND TUBE SPACING.

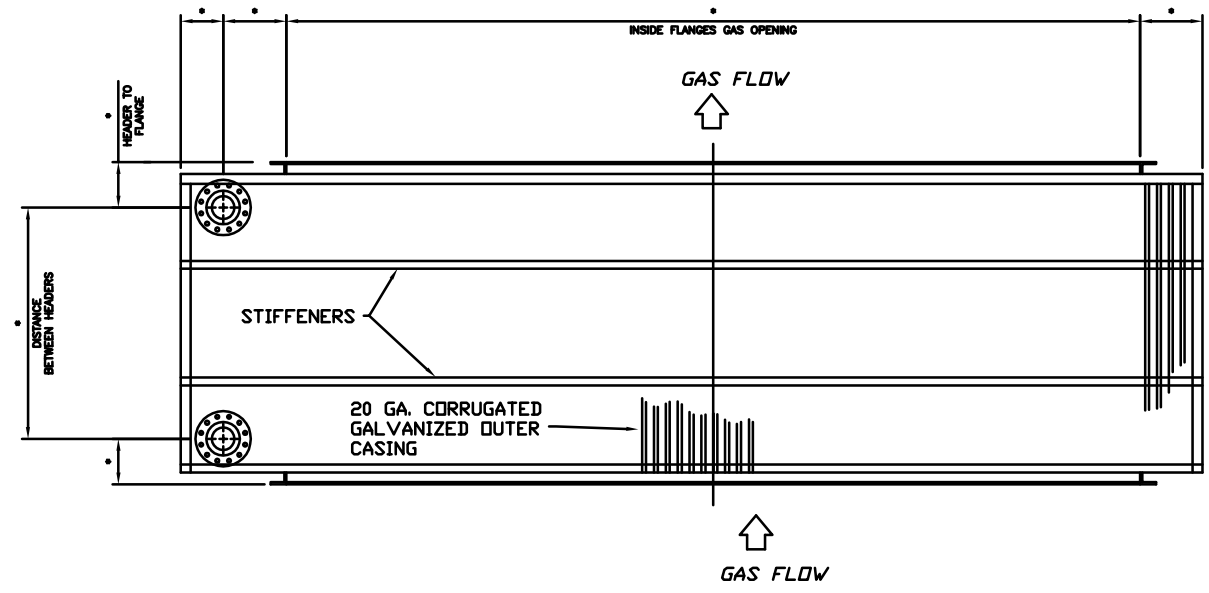

SIDE VIEW

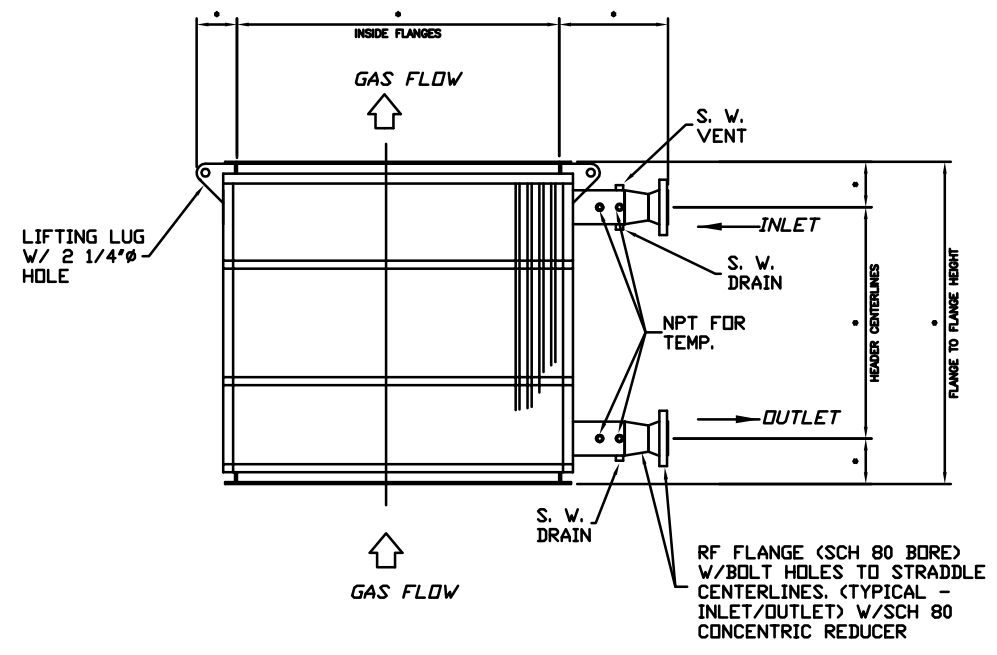

END VIEW



GENERAL ARRANGEMENT SERIES:
 VERTICAL FLOW ECONOMIZER SAMPLE

-BASIC ECONOMIZER-

SCALE: NONE	DATE: MAY 10, 2007
DRAWN BY: KENB	CHECKED:
JOB NO: PROPOSAL	SERIAL NO:
QTY:	DRAWING NO: ECON SAMPLE