

NOTES:

1. DRAWING IS FOR OVERALL SIZE AND ARRANGEMENT ONLY. REFER TO PROPOSAL FOR ACTUAL TRIM LIST.
2. DRAWING IS NOT TO BE USED FOR CONSTRUCTION PURPOSES.
3. FEEDWATER SIZING AND LOCATIONS OF VALVES AND PIPING IS A REPRESENTATION ONLY, AND IS USED TO SHOW AN EASILY VISIBLE PICTORIAL VIEW.
4. * - DENOTES TO BE DETERMINED.

DO NOT SCALE - USE DIMENSIONS ONLY *TYP./B.O. INDICATES NOT FURNISHED BY CB NB
 DO NOT USE FOR CONSTRUCTION UNLESS APPROVED BELOW
 THIS DRAWING IS THE PROPERTY OF CB NEBRASKA BOILER AND IS LOANED ON CONDITION THAT IT SHALL NOT BE COPIED OR REPRODUCED IN WHOLE OR IN PART OR DISCLOSED TO ANY THIRD PARTY OR USED IN ANY WAY WITHOUT THE WRITTEN CONSENT OF CB NEBRASKA BOILER. ANY EQUIPMENT OR MATERIAL SHOWN, BUT NOT FURNISHED BY CB NEBRASKA BOILER, IS FOR ILLUSTRATING THE APPLICATION, AND CB NEBRASKA BOILER ACCEPTS NO RESPONSIBILITY AS TO INSTALLATION OR OPERATION OF SUCH EQUIPMENT OR MATERIALS.

REV.	DATE	DESCRIPTION	DWN	CHK	APPR

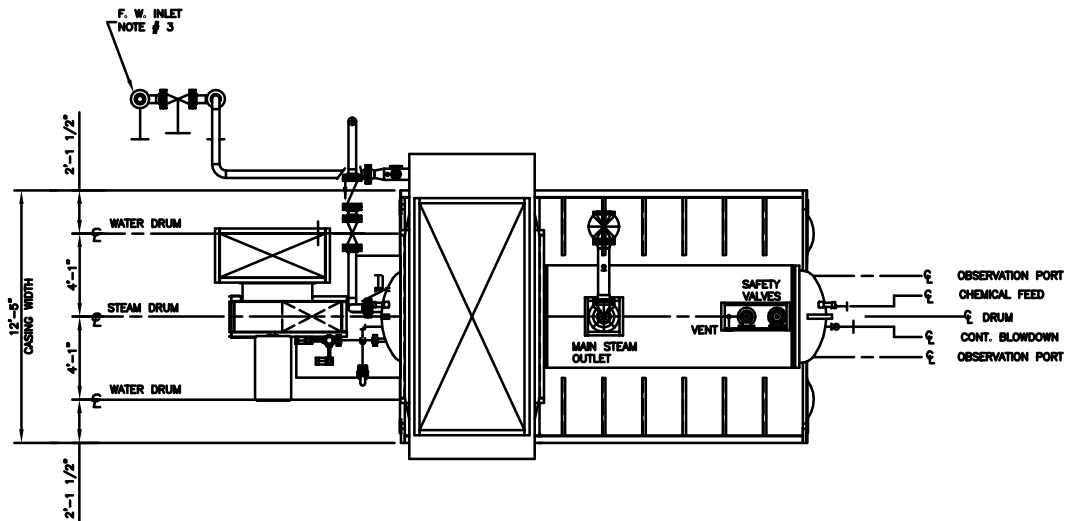

PLAN VIEW

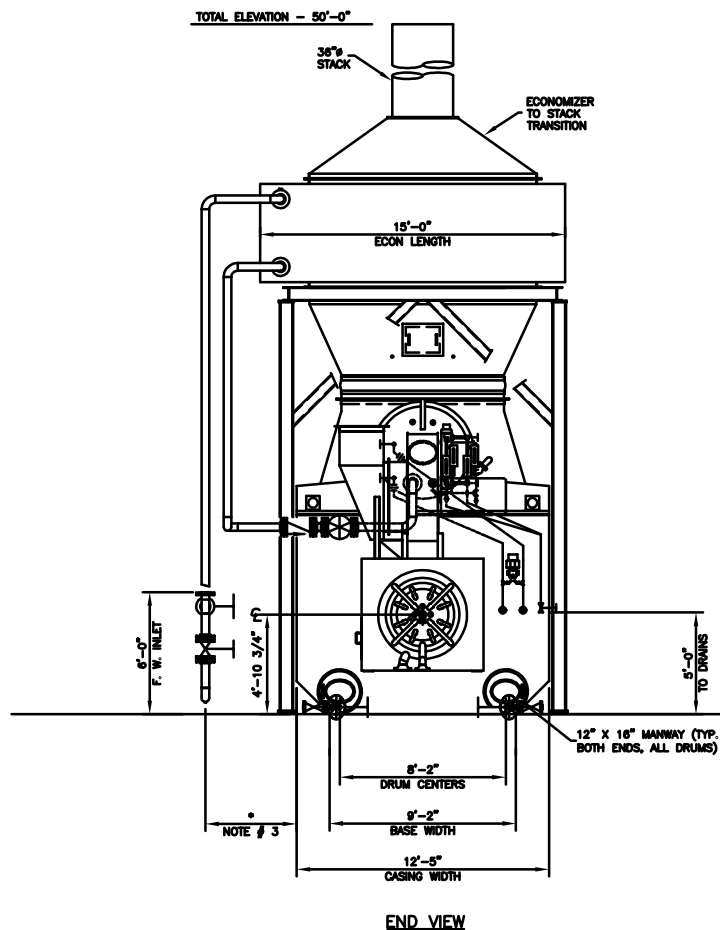

END VIEW

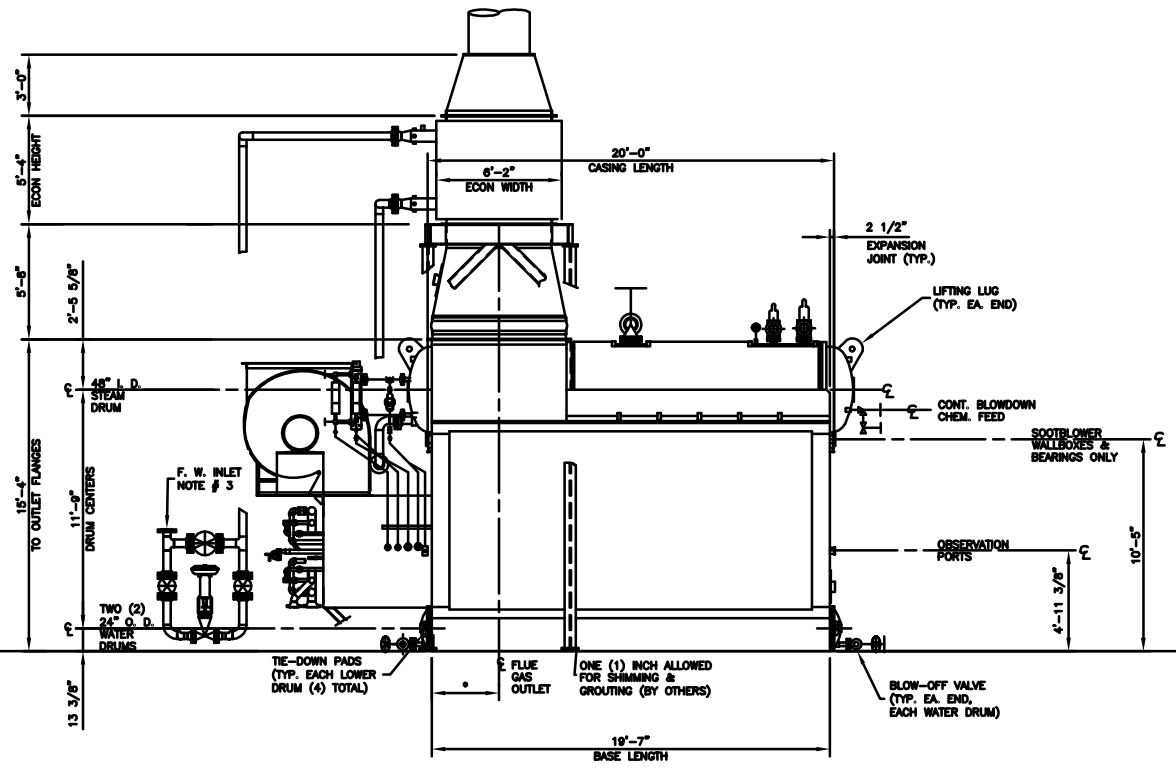

SIDE VIEW



GENERAL ARRANGEMENT SERIES:
 N2S-7/S-55 W/ECON (HM)

LAYOUT DRAWING FOR
 60,000 LB./HR.

SCALE: NONE	DATE: MAY 10, 2007
DRAWN BY: KENB	CHECKED:
JOB NO: PROPOSAL	SERIAL NO:
QTY:	DRAWING NO: N2S-7S-55